

TO INCREASE THE STABILITY OF A TRACTOR BY INCREASING THE ADHERENCE WEIGHT

Author- Ashish Dewangan

Abstract— Rollovers account for more than half of these fatalities, despite decades of effort by tractor manufacturers and farm safety professionals to eliminate these tragedies. Driving too close to an incline or embankment, driving too fast when negotiating a curve, driving the tractor with a loaded front-end loader in the raised position, uneven braking while traveling at high speeds, and losing control of the tractor due to excessive load on the drawbar are the major causes of side rollovers. Center of gravity must lie inside the stability baseline area. From the time the tractor begins to rollover, the incident can take as little as 1.5 seconds. This can be prevented by increasing the weight on front wheel axel. We find that this can be done by using water filled tires on front wheel and for further increasing the weight we can use magnesium chloride (MAG) as an additive. MAG can increase the weight of water filled the tire about 20%, also it is a good antifreeze mixture which proved to be useful if we use water filled tire along with MAG in low temperature zone.

Index Terms— Drawbar; Entanglements ; MAG; Run overs ; Rear rollovers ;Side rollover; Stability baseline.

1. INTRODUCTION

No other machine is more identified with the hazards of farming as the tractor. Nearly 50% of tractor fatalities come from tractor overturns tractors are used for many different tasks. Because the tractor is a versatile machine, operators sometimes stretch the use of the tractor beyond what the machine can safely do.

2. HOW TRACTOR OVERTURNS

Centre of gravity (CG). A Centre of gravity is the point where all parts of a physical object balance one another. From figure1 shows that the CG is inside a tractor's stability base line. Drawing a line to connect all the wheels of the tractor as the wheels set on level ground. The CG moves around inside the baseline area as we operate the tractor shown in figure 2.

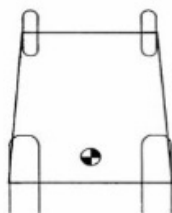

Figure 1: Stability baseline

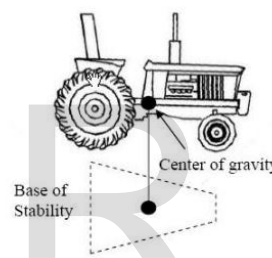

Figure 2: Stability baseline showing CG

3. SIDE ROLLOVERS

Gravity and centrifugal force are the two major forces involved in a sideways rollover. Backflips are produced through rear axle torque and drawbar leverage. Several concepts need to be understood in order to manage the hazard of tractor rollovers and backflips. Sideways rollovers occur most commonly when traversing a steep slope or cornering too sharply at speed. Two concepts which are useful in understanding sideways rollovers are the relationship between the tipping of the tractor and its Centre of gravity together with the amount centrifugal force developed during cornering.

The tipping axis is the line that a tractor will pivot about during tipping if driven over a steep enough slope. This is more easily understood if we look at the crawler tractor. The tipping axis on a crawler tractor is at the outside edge of the track. The tipping axis of a 2WD and 4WD tractor is more complicated. This is because the front axle is attached to the tractor chassis by a central pivot point. Thus, as the tractor tips, it has two tipping axes.

The most important one is in a line from the outside edge of the rear wheel to the central pivoting point of the chassis. This axis line continuous to where the axle hits the chassis when the tipping axis moves to the outer edge of the front and rear wheels. When the tractor reaches this second axis, it is usually past the point of no return. The Centre of gravity is the point where all parts of the tractor balance one another. If a tractor could be suspended from the Centre of gravity it would be perfectly balanced. The position of the Centre of gravity will change if any implements are added, removed or change position. If a bucket is raised, it will raise the Centre of gravity and the bucket is lowered, the Centre of gravity will also be lowered. Thus, the Centre of gravity moves toward the weight change. The Centre of gravity is normally located in the vicinity of the gearbox in the mid-line of the tractor. The Centre of gravity is useful for assessing the stability of a tractor when combined with the tipping axes. If a plumb bob(a weight on the end of string) is suspended from the Centre of gravity, it will demonstrate its position in relation to the tipping axes. As the Centre of gravity is raised, it takes a lesser slope to the breach the tipping axes. Once the Centre of gravity lies outside the tipping axes, a rollover is inevitable. Centrifugal force is introduced when a tractor is cornering. This force tends to pivot the tractor on its outside wheels during cornering. This pre-disposes the tractor to a rollover. An example of centrifugal force is the force that pushes you to the outside of the car when going around a corner. The faster you go, the greater the force. The centrifugal force (mv^2/r) varies according to the weight of the tractor, the speed and the turning angle. The force will increase as the angle of turn becomes sharper. Halving the radius of the corner will double the centrifugal force similarly, doubling the speed from 5 km/h to 10 km/h would increase the centrifugal force four times ($2^2=4$). Tripling the speed from 5 km/h to 15 km/h would increase the force nine times ($3^2=9$).

Centrifugal force is a factor contributing to a tractor upsets on flat ground. It is also important when operating on slopes. When a tractor is turning on slopes. When a tractor is turning on slopes its Centre of gravity may be approaching its tipping axes, and it may only require a small amount of centrifugal force to cause a rollover. There has often been contention about the correct direction to turn when crossing a hill slope. Remember that when the direction of turning is being discussed with reference to slopes, none of the turns should be sharp. Rather, they should be veering off in an uphill or downhill direction. If the turn is too sharp, there will be large centrifugal forces involved.

4.BACK FLIPS

The second type of rollover is backflip. In this scenario, there are two forces in action. This are rear axle torque and drawbar leverage. Rear axle torque is the transfer of energy between the engine and rear wheels of a tractor. It occurs when pinion gear in the differential meshes with the crown wheel of the axle. Thus, the pinion which is

driven by the engine applies a rotational force to the wheels via the crown wheel. This may be described as the rear axle rotate with respect to the chassis pulling a heavy load.

Practices which involve rear axle torque reactive force acting to cause a backflip include:

- Driving off in low gear but with high engine speed.
- Attempting to drive the tractor forward when the wheels are unable to move forward.
- Rapid engagement of the clutch of the tractor.

The weight of the load carried by the tractor combined with that of the tractor make up the gross vehicle mass. Where front-mounted lifting attachments are attached to a tractor, drivers need to be aware of the load-bearing limit on the tractor axle and ensure those limits are not exceeded. If a loader is overloaded, the weight vehicle mass will be entirely on the front axle and can lead to a backflip. Check their recommended load limits in the driver's manual. If you are still not sure, ask the tractor distributor.

5. PREVENTING ROLLOVERS

Tractor design features are available that reduce the risk of rear rollovers. Some features come standard on new tractors, while others are optional to be employed in specific circumstances to maintain proper weight balance. This includes rear wheel weight, tire ballast, front-end weights and fixed drawbar height. To reduce the risk of a rear rollover, tractor operators should:

- Keep front-end loader buckets low when pulling rear mounted loads.
- At front-end weights when raising heavy rear mounted equipment.
- Backup steep hills and driving forward down steep hills.
- Hitch loads only to the drawbar and never hitch loads above the draw bar

6.PREVENTING SIDE ROLLOVER

Today, tractor manufacturers attempt to prevent side rollovers through design features and tractor options that widen the base of stability and lower the tractor's Centre of gravity. Some of these features include:

- Wide front-end design versus narrower tricycle-typed designs.
- Adjustable rear wheel width and dual wheel tractors.
- Wide tires.
- Ability to lock brakes together.

To reduce the potential of a side rollover, tractor operator should:

- Drive at appropriate speeds.
- Set wheel tread as wide as possible.

- Stay away from steep slopes, ditches, and embankments.
- Keep front-end loader buckets low during transport or when turning.
- Lock brakes together when travelling at high speeds.
- Drive forward down steep slopes and backup them slowdown when pulling rear-mounted equipment.

$$\frac{WS}{P} = \frac{k}{GTR}$$

Table 1- Logical values of "k"

Units	m/s	Mph	Km/h
Kg/KW	106	-----	383
lb/hp	-----	375	630

For all practical purpose assuming GTR=0.45.

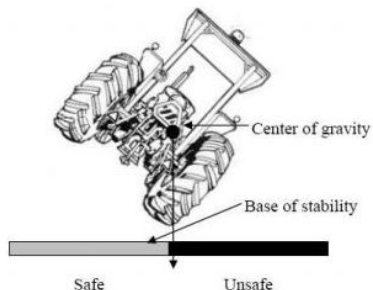

Figure 3: Side rollover

7.BALLASTING

Ballasting is weight added to the tractor for the purpose of improving tractors performance. Depending on the field condition and the drawbar requirements of the operation, the tractors unballasted weight may actually heavier than the optimal weight. Agricultural tractor ballasting recommendations have evolved over years.

In the early 1970's, John Deere published a slide rule (OBM-20R2) to calculate recommended tractor weight based on available power and speed of operation.

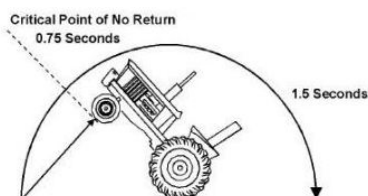

Figure 4: Rear rollover

Dwyer (1984) stated that " for a surprisingly wide range of tires and soil conditions it has been found that tractive efficiency reaches a maximum at a coefficient of traction of about 0.4". The relationship for weight, power, and speed is:

$$\frac{(\text{weight})(\text{speed})}{\text{power}} = \frac{WS}{P} = \frac{TE}{NTR}$$

Where, T = traction efficiency

NTR = net traction ratio

GTR= gross traction ratio

7.CENTRE OF GRAVITY OF TRACTOR

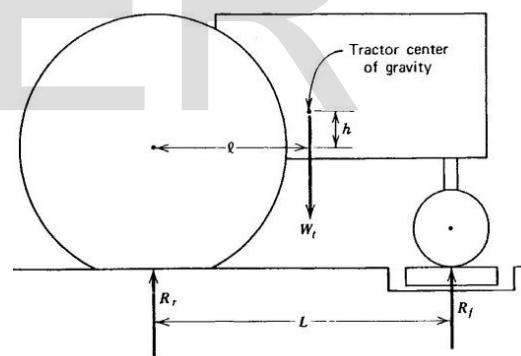

Figure 5: Showing Centre of Gravity



Figure 6: Tractor

Determination of Centre of gravity:-

Wt = Weight of tractor

l = Centre of gravity in x-direction

R'f = Reaction of front wheel

L = Wheel base

Δr = Difference of radius of front and rear wheel

$$l' = l \cos \lambda - h \sin \lambda$$

$$h = \frac{(Wt * l) - R_f(L + \Delta r \tan \lambda)}{Wt \tan \lambda}$$

$$h = \frac{(Wt * l) - (R'_f * L)}{Wt \tan \lambda} - \frac{R'_f * \Delta r}{Wt}$$

For all practical purpose it is proved that $\lambda = \lambda_1 + \lambda_2$

Now,

$$\tan \lambda_1 = \frac{u - r_r}{L'}$$

u = Height of inclination

$$\frac{R'_f L'}{Wt} = l \cos \lambda - h \sin \lambda \text{-----1}$$

$$L' = (L + \Delta r \tan \lambda) \cos \lambda \text{-----2}$$

$$\frac{R'_f (L + \Delta r \tan \lambda) \cos \lambda}{Wt} = l \cos \lambda - h \sin \lambda$$

$$\frac{R'_f (L + \Delta r \tan \lambda)}{Wt} = l - h \tan \lambda$$

$$\tan \lambda_2 = \frac{\Delta r}{L}$$

$$L' = \sqrt{L^2 + \Delta r - (u - r_r)^2}$$

$$Z_{cg} - \Delta r = \frac{W_t l - R'_f L}{W_t \tan \lambda} - \frac{R'_f \Delta r}{W_t}$$

$$Z_{cg} = \frac{W_t l - R'_f L}{W_t \tan \lambda} - \frac{R'_f \Delta r}{W_t} + \Delta r$$

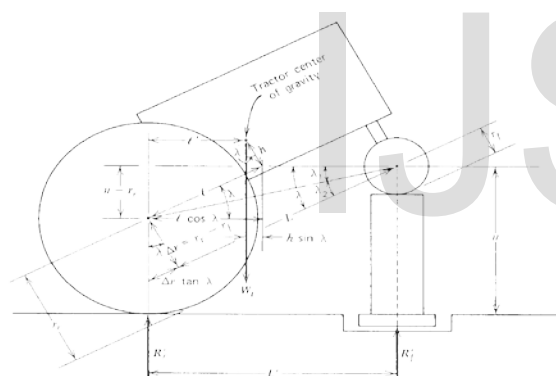

Figure7: Centre of gravity of tractor

8. MAG FOR TIRE BALLASTING

Using the tire ballast is important for a number of reasons:

- Increased traction
- Increased tractor life
- Increased tire life
- Greater fuel economy
- Greater convenience

Table: 2 volume and weight are based on 100% fill with a 22% solution of MAG for radial tire and tire bearing varying loads, a 75% fill is recommended.

Tire size	Gallons of standard solution	Weight added to tire (lb.)
20.50-25	124	1240
21.00-24	160	1600

Tractor specifications are:-

$$W_t = 2440 \text{ kg} = 23936.4 \text{ N}$$

$$R_f = 930 \text{ kg} = 9123.3 \text{ N}$$

$$R_r = 1510 \text{ kg} = 14813.1 \text{ N}$$

$$r_f = 254 \text{ mm}$$

$$r_r = 355.6 \text{ mm}$$

$$\Delta r = 101.6 \text{ mm}, L = 2150 \text{ mm}$$

If we lowered down the center of gravity of a tractor by reducing the chassis length we get certain result:-

Center of gravity is comes down to 250mm when length of chassis reduces to 139.1625mm

But this result is not desirable until we increase the adherence weight to increase the traction of tractor therefore we proceed further our experiment to increasing the center of gravity

We use water filled tire on the front axle of tractor, the specimen model we us is a tractor of HMT which is one of the most widely used tractor in India for agriculture purpose.

Z(mm)	L(mm)	change in chassis length(mm)
262	2047.3197	102.68033
260	2026.8727	123.12733
258	2006.4257	143.57433
256	1985.9787	164.02133
254	1965.5317	184.46833
252	1945.0847	204.91533
250	1924.6377	225.36233
248	1904.1907	245.60933
246	1883.7437	266.25633
244	1863.2967	286.7033
242	1843.8497	307.15039
240	1822.4027	327.59733

Along with the water we also added magnesium chloride as a additive because:-

- It increases the weight of water solution by 20%
- It is an antifreeze mixture which drops down the freezing point of water to -27⁰F

Now experimental analysis:-

Tire size- 7.00-20

Gallons of standard solution= 10

Weight added to tire= 100lb

In two tires total weight=200lb=90.7184kg
 =889.9483N

Total weight of tractor= 23936.4+889.948=24826.348N

Distance of center of gravity from rear wheel axel= $l = \frac{R_f L}{W_t}$

$R_f = 10013.24829N$

$R_f' = 9739.023976N$

$l = 867.1627mm$

Aftersolving we get $(Z_{cg} - 61.74376) * 10.2235 = L$

9.ANALYSIS

When we added water to the front tire, and try to lower the center of gravity about 250mm from the wheel base then we have to take the chassis length is 1924.63767mm which is 225.36233mm smaller than previous length. The change in the dimension can be easily done.

Increasing the weight to the front wheel axel tends to increase the adherence between ground and wheel also the traction of tractor.

Comparison before and after the experiment:-

Before experiment (ballasting):-

Z(mm)	L(mm)	change in chassis length(mm)
260	2118.9105	31
258	2097.2959	52.7
256	2075.6814	74.3186
254	2054.0667	95.93
252	2032.452	117.5478
250	2010.8375	139.1625
248	1989.2229	160.7771
246	1967.6087	182.3916
244	1945.9937	204.0063
242	1924.3791	225.6204
240	1902.7646	247.2354

After experiment (ballasting):-

Before ballasting:-

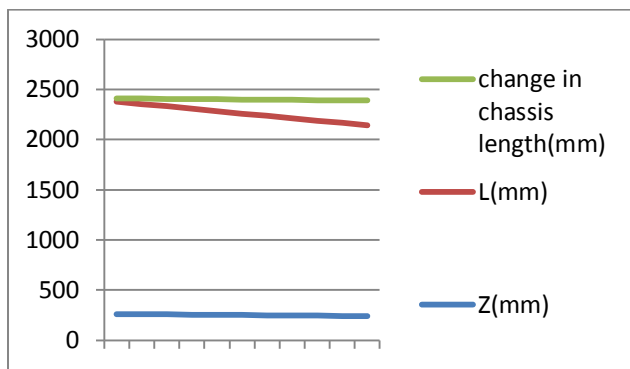

Z(mm)	L(mm)	change in chassis length(mm)
262	2047.3197	102.68033
260	2026.8727	123.12733
258	2006.4257	143.57433
256	1985.9787	164.02133
254	1965.5317	184.46833
252	1945.0847	204.91533
250	1924.6377	225.36233
248	1904.1907	245.60933
246	1883.7437	266.25633
244	1863.2967	286.7033
242	1843.8497	307.15039
240	1822.4027	327.59733

After ballasting:-

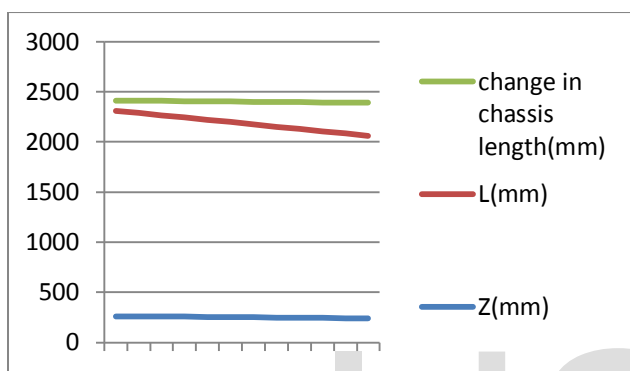

From the graphical representation it is clearly seen that there is very small variation in chassis length if we ballast tire with water with MAG as additive. But this will increase the adherence weight as well as increase the stability of a tractor.

10.CONCLUSION

Our main objective in this paper is to provide stability to a tractor by increasing the adherence weight as well as shifting the center of gravity in horizontal and vertical directions. We mainly focused on increase the adherence weight by increasing the weight by using water filled tires in front wheel rim, weight can further be increased by mixing MAG in water which increases the weight of water approximately by 20%. for eg: one gallon of water weights about 8.3lb after adding MAG the weight increases up to 10lb.

11.REFERENCES

[1]WC Harshman, AM Yoder, JW Hilton and DJ Murphy, "Tractor stability", The Pennsylvania State University. Reviewed by TL Bean and D Jensen, The Ohio State University and S Steel, National Safety Council. Version 4/2004.

[2]Erlich, M. Driscoll, T. Harrison, J. Frommer, M. & Leigh, "Tractor Rollovers", work related Agricultural fatalities in Australia. 1982-84 Scandinavian Journal of Environmental Health. 1993. 19 pp162-67 .

[3]David W.Smith,"Safe Tractor Operation", Extension Safety Program AgriLIFE EXTENSION Texas A&M System.

[4]TOTAL ICE CONTROL Dead Sea works potash house, POB 75, Beer Sheva 84100 Israel